

Power Electronics – May 2005

Time : 3 Hrs.]

[Marks : 100

- N.B. :** (1) Q. No. 1 is compulsory.
(2) Attempt any four out of remaining six questions.
(3) Support your answer with neat Block/Circuit diagrams and wave forms wherever necessary.

1. Explain briefly (any five) :- [20]
 - (a) 'SOA' Ratings of the Power Transistors.
 - (b) Output Characteristics of an N-Channel IGBT.
 - (c) Need of Electrical Isolation between gate and driver circuit.
 - (d) How protection is offered to an SCR against excessive di/dt ?
 - (e) How SCR is protected against over-voltage ?
 - (f) Need of cooling of a Power Device
2. (a) Draw and design the UJT Triggering Circuit. The parameter of the UJT are $V_{BB} = 30V$, $\eta = 0.51$, $I_P = 10\mu A$, $V_V = 3.5V$, and $I_V = 10mA$, the frequency of oscillations is $f = 60$ Hz, and width of the triggering pulse is $t_g = 50 \mu s$. Assume $V_D = 0.5V$ [10]
(b) Draw and, explain the working of 3 Phase Uncontrolled Bridge Rectifier with purely resistive load and derive the expression for the Average Output Voltage and sketch the input and output' wave forms with proper sequence of conducting diodes. [10]
3. (a) Based on either 'Inverse Cosine' OR 'Pedestal and Ramp' principle. Suggest a detailed firing circuit to trigger four SCR's of 1ϕ Fully controlled Bridge Converter. Comment on; how synchronization; Isolation and Phase Control is achieved. [12]
(b) A half wave controlled rectifier is connected to a 120 V source. Calculate the firing angle necessary to deliver 150 W of power to a 10Ω load. [8]
4. Draw the circuit and wave forms across SCR and load at $\alpha = 60^\circ$ and explain working of single phase fully controlled bridge converter with :- [20]
 - (a) Pure Resistive load.
 - (b) R-(10) L (Highly Inductive).
 - (c) R-L load (Low Inductive).
 - (d) R-L load with free wheel diode.Write the average output voltage expression for each.
5. (a) Explain with diagram the working of Parallel Inverter. Explain the need for feedback diodes and pulse train for firing of SCR's. Draw capacitor, SCR and Load voltage wave forms. [10]
(b) Draw the circuit and important wave forms and explain the working principle of operation of a Jones Chopper. [10]
6. (a) Speed of a DC Motor operating on 230V DC supply is to be controlled by Converter fed armature voltage control' method. Draw the relevant circuit diagram of controller and explain its operation with proper wave forms. [10]
(b) Draw and explain the 'Variable Voltage and Variable frequency¹ (V/f) method of speed control for 3 phase Squirrel Cage Induction Motor. What is the significance of (V/f) ratio control. [10]
7. (a) Explain with block schematic the working of Micro Controller based control circuit of motor control. [8]
(b) Discuss about selection of R in Snubber Circuit Resistance. A Thyristor has a current as 200A while dv/dt capability is 60v/ μsec . A three phase six pulse converter circuit is fabricated with the Thyristor. If the circuit inductance being 0.15mH. Design a Snubber Circuit. [12]

Or

 - (c) Write short notes (any two) :- [12]
 - (i) Types of cooling of a power Device,
 - (ii) Opto Isolators.
 - (iii) Slip power recovery control of 3 phase IM.
 - (iv) IR Compensation

○ ○ ○

Power Electronics – December 2005

Time : 3 Hrs.]

[Marks : 100

- N.B. :** (1) Q. No. 1 is compulsory.
(2) Attempt any four out of remaining six questions.
(3) Support your answer with neat Block/Circuit diagrams and waveforms wherever necessary.
(4) Assume suitable data wherever required but clearly state and justify it.

1. Explain briefly (any five) :- [20]
 - (a) 'SOA' Ratings of the Power devices.
 - (b) Compare SCR and IGBT.
 - (c) Why isolation is usually used in gate circuit of SCR? Give various techniques used for isolation.
 - (d) Explain $\frac{dv}{dt}$ ratings of SCR and give protection circuit used for this ratings.

- (e) Explain what is device turn off time and circuit turn off time, which of these should be larger for satisfactory operation of circuit in inverter? Give reason.
- (f) Need of cooling of a Power Device.
2. (a) Give the basic requirements for successful firing of an SCR. Draw the circuit of synchronized UJT triggering (ramp triggering) of SCR. Describe its working giving relevant voltage waveforms. [12]
- (b) Draw and explain the working of three phases Delta–Wye Bridge Rectifier. Draw the waveforms or rectified voltage and write expression of it. [8]
3. (a) Explain the ‘Slip Power Recovery Control’ of three phase Induction motor . [10]
- (b) In a single phase full converter which uses a delay angle control and is supplied by a 230 V; 50 Hz input. If $\alpha = \pi/3$, Load resistance $R = 10$ ohms, Load inductance $L = 20$ mH, determine the average output voltage, output current and load impedance. [10]
4. (a) Explain the working of an TRIAC and DIAC. Also explain their V–I characteristics. [8]
- (b) Draw and explain the ‘fan regulator’ circuit using DIAC and TRIAC. Draw and explain the voltage waveforms across TRIAC and load. [12]
5. (a) Explain with diagram the working of Series–Inverter. What are the limitations to this circuit. How these limitations are improved. [12]
- (b) Explain with block schematic the working of Micro–controller based control circuit of motor speed. [8]
6. (a) Draw the circuit of single phase bridge semiconverter with freewheel diode. Describe its working and draw waveforms for various voltages and currents involved. [10]
- (b) How will you employ the circuit of Q. 6(a) to control the speed of separately excited DC motor? Draw the circuit with motor as load and show the motor voltage waveform. [10]
7. (a) Write short notes (any **three**) : [18]
- (i) Inverse cosine triggering circuit for SCR.
- (ii) Jones Chopper.
- (iii) $\frac{V}{f}$ control of three phase Induction motor.
- (iv) Opto Isolator
- (v) Commutation circuit for SCR.
- (b) Define Latching current and Holding current relevant to SCRs [2]

○ ○ ○

Power Electronics – May 2006

Time : 3 Hrs.]

[Marks : 100

- N.B. :** (1) Q. No. 1 is **compulsory**.
 (2) Attempt any **four** questions from the remaining questions.
 (3) Assume **suitable** data wherever **necessary**.

1. Explain in brief :- [20]
- (a) State the conditions for getting Inversion mode operation in case of line commutated converters.
- (b) Why commutation failure may occur in Jones Chopper ? How it can be avoided?
- (c) What is the Half waving effect in case of symmetrical Half Controlled Bridge Rectifier ? How it can be taken case of ?
- (d) What are the different performance parameters for controlled Rectifiers ? Explain their significance.
- (e) Explain the importance of $\frac{dv}{dt}$ and $\frac{di}{dt}$ ratings along with proper protection circuit in case of SCR.
2. (a) In case of fully controlled Bridge Rectifier (Single phase) assuming continuous conduction with ripple free output current feeding an active load. Draw the following waveforms, at $\alpha = 90^\circ$. [10]
- (i) V_{out} i.e. output voltage
- (ii) I_{out} i.e. output current
- (iii) I_s i.e. Input supply current
- (b) What is the effect of source inductance on the output voltage of full wave controlled Rectifier. Obtain an expression for the output voltage with the effect of source inductance. [10]
3. (a) Draw the diagram of Basic series Inverter and explain its operation. State its limitation. How the output frequency can be made equal to ringing frequency in case of modified series Inverter. [10]
- (b) The modified series Inverter has $L_1 = L_2 = L = 50\mu H$, $C = 6\mu f$ and $R = 2\Omega$. The D. C. input voltage is 220V and the frequency of output voltage is $f_0 = 7KHz$. The turn off time of SCR is $t_q = 10\mu sec$. Determine (a) the circuit turn off time t_{off} (b) the maximum possible frequency with given SCRs. [10]
4. (a) Explain the operation of Jones Chopper along with the waveform across load and capacitor voltage. Also obtain an expression for circuit turn-off time available (t_{off}) so as to select SCRs with proper turn-off time ratings. [10]

- (b) A highly inductive load controlled by voltage commutated chopper requires max. load current $I_m = 450\text{Amp}$. The output supply voltage is $V_s = 200\text{V d.c}$. The chopping frequency is $f = 400\text{Hz}$ and the turn off time of SCR $t_q = 20\mu\text{sec}$. If the peak current through the main SCR is limited to 170% of I_{max} . Determine (i) Commutating Capacitance C (ii) Inductance L (iii) Minimum output voltage possible. [10]
5. (a) Explain the method of speed control of 3 ϕ Slip Ring Induction Motor using Slip Power Recovery scheme. What should be range of firing angle for this scheme. [10]
 (b) The speed of a separately excited D. C. Motor is controlled by a semi converter (Half Controlled Bridge). The field current which is also controlled by a semiconverter is set to the maximum possible value. The a. c. input voltage is 230V, 50Hz. The armature resistance $R_a = 0.25\Omega$, field resistance $R_f = 147\Omega$ and the motor voltage constant is $KV = 0.7032\text{V/A-rad/sec}$. The load torque is $T_L = 45\text{N-M}$ at 1000rpm. Assume Armature current to be continuous and ripple free. Calculate :- (i) the field current I_f
 (ii) the delay angle of converter in the armature circuit. [10]
6. (a) Draw the neat diagram for 3 ϕ semiconverter feeding Highly Inductive load. Assuming continuous and ripple free output current. Draw the output voltage waveform for $\alpha = 30^\circ$, measured from natural angle delay. i.e. $\pi/6$. Clearly show the conducting sequence of the devices. [10]
 (b) Explain UJT triggering circuit for triggering of 2 SCRs used in full-wave controlled Rectifier, with proper Isolation. What is the need of synchronization circuit? [10]
7. (a) What are the various sources of power loss in power semiconductor devices. A Thyristor with a steady state power loss of 30W has a junction to heat sink thermal resistance of 0.7°C/w . Determine the maximum value of Thermal Resistance the heat sink can have if the ambient temperature is 40°C and junction temperature is limited to 125°C . [10]
 (b) Explain the operation of Fan Regulator circuit using Triac-Diac. Draw the output voltage waveform. State in which modes Triac is operating in this circuit. [10]

○ ○ ○

Power Electronics – December 2006

Time : 3 Hrs.]

[Marks : 100

- N.B. : (1) Attempt any **five** questions out of **seven** questions.
 (2) Illustrate answers with sketches whenever **required**.

1. (a) Explain single phase full wave converter with R–L load. Draw the necessary wave forms (use $\alpha = 120$). [10]
 (b) Define Holding Current and Latching Current in SCR. Explain the V–I characteristics of SCR [10]
2. (a) Explain Jone’s Chopper in detail with necessary waveform. [10]
 (b) Explain basic Series inverter with waveforms [10]
3. (a) Explain the full wave A.C. Control using TRIAC and DIAC. Draw waveforms. [10]
 (b) Explain R and RC triggering methods for SCR. Draw neat waveforms. [10]
4. (a) How di/dt and dv/dt protection is achieved for SCR? [10]
 (b) The series inverter has $L_1 = L_2 = L = 50\ \mu\text{H}$, $C = 6\ \mu\text{F}$, $R = 2\ \Omega$. The d.c. input voltage is $V_s = 220\ \text{V}$ and the frequency of output voltage is $f_0 = 7\ \text{KHz}$. The turn–off time of thyristor is $t_q = 10\ \mu\text{sec}$. Determine : (i) Circuit turn–off time t_{off}
 (ii) The maximum permissible frequency f_{max}
 (iii) The peak–peak capacitor voltage
 (iv) The peak load current I_p . [10]
5. (a) Explain three phase converter with R load. [10]
 (b) A load commutated chopper, fed from a 230 V d.c. source has a constant load current of 50 Amp. [10]
 For a duty cycle of 0.4 and chopping frequency of 2 KHz.
 Calculate: (i) The value of commutating capacitance
 (ii) Average output voltage
 (iii) Circuit turn–off time for one SCR pair
 (iv) Total commutation interval.
6. (a) Explain in detail step–up chopper and step down chopper with the help at diagram, waveform and mathematical analysis. [10]
 (b) Explain electrical analog model of heat transfer and explain different cooling techniques. [10]
7. Write a short notes on any **two** : [20]
 (a) Microprocessor based d.c. motor speed control.
 (b) V/F control for induction motor.
 (c) Slip power recovery scheme.

○ ○ ○

Power Electronics – May 2007

Time : 3 Hrs.]

[Marks : 100

- N.B.** (1) Q. No. 1 is compulsory.
 (2) Attempt any **four** questions from the remaining **six** questions.
 (3) Assume **suitable** data if **required**.
 (4) Illustrate answers with sketches whenever required.

1. Explain in brief (any four) : [20]
 (a) Explain the importance of dv/dt and di/dt ratings of SCR.
 (b) Compare BJT, SCR and IGBT.
 (c) What is an inverter? List a few industrial applications of inverters.
 (d) What is the basic principle of dc chopper operation? Derive an expression for its average dc output voltage.
 (e) Explain the need of commutation in thyristor circuits. What is voltage commutation and current commutation?
 (f) What is Latching current, Holding current, Forward break-over voltage, Reverse break-over voltage of a Thyristor.
2. (a) Explain the full wave A.C. control using TRIAC and DIAC. Draw waveforms. [10]
 (b) Explain inverse cosine triggering circuit for SCR. How triggering angle α is changed? [10]
3. (a) (i) A single phase controlled rectifier bridge consists of one SCR and three diodes as shown in the diagram. Sketch output voltage waveform for a firing angle $\alpha < 90^\circ$ for SCR and obtain expression for average output voltage under the assumption of continuous current. [10]
 (ii) Draw waveforms of current through T_1 , D_1 , D_2 and D_3 and I_L , if $V_s = V_m \sin \omega t$.
 (iii) If ac source voltage is 230 V; 50 Hz and firing angle 45° find average output current and power delivered to battery in case Load is of $R = 5 \Omega$, $L = 8 \text{ mH}$ and $E = 100 \text{ V}$.

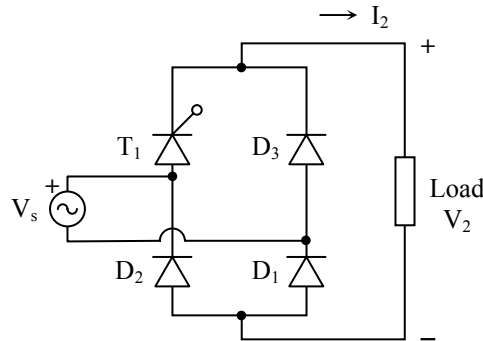

- (b) Draw and design the UJT triggering circuit. The parameters of the UJT are : [10]
 $\eta = 0.72$, $I_p = 0.6 \text{ mA}$, $V_p = 18 \text{ V}$, $I_V = 2.5 \text{ mA}$, $V_V = 1.0 \text{ V}$, $R_{BB} = 5 \text{ K}\Omega$. Normal leakage current with emitter open = 4 mA. The firing frequency is 2 kHz. For $C = 0.4 \mu\text{F}$ compute the values of resistors. It is required to change the firing frequency by varying charging resistor R , obtain maximum and minimum values of R and corresponding frequencies.
4. (a) Explain the operation of Jones Chopper along with the waveforms across load and capacitor voltage. Obtain an expression for circuit turn-off time available so as to select SCRs with proper turn-off time ratings. [10]
 (b) A voltage commutated chopper feeds power to a battery-power electric car. The battery voltage is 60 V, starting current is 60 A and thyristor turn-off time is 20 μsec . Calculate the values of the commutating capacitor C and L . Also find Peak current through main thyristor, auxiliary thyristor. [10]
5. (a) Draw the circuit diagram and explain working of basic simple single phase parallel inverter without feedback diodes. Draw waveforms for V_c , I_c , voltage and current of a thyristor and output voltage and current. [10]
 (b) Calculate the output frequency of a series inverter with $L = 6 \text{ mH}$, $C = 1.2 \text{ mF}$ and $R = 100 \Omega$, $T_{\text{pff}} = 0.2 \text{ ms}$. If the load resistance is varied from 40Ω to 140Ω find out the range of output frequency. [10]
6. (a) Explain four quadrant operation of a dc drive. How this operation will be achieved? What types of controlled rectifiers will be needed? Suggest the control strategy for the same. [10]
 (b) Explain slip-power recovery scheme in a.c. drives. [10]
7. Write short notes on any **four** : [20]
 (a) V/F control for Induction motor.
 (b) Ramp and Pedestal scheme for triggering SCR.
 (c) Ratings of SCR.
 (d) Effect of source inductance on output voltage of full controlled rectifier.
 (e) Class B commutation of SACR.
 (f) Turn On & Off time of SCR.

○○○

Power Electronics – December 2007

Time : 3 Hrs.]

[Marks : 100

- N.B.:**
- (1) Question No.1 is **Compulsory**.
 - (2) Attempt any **four** questions from remaining **six** questions.
 - (3) Figures to the **right** indicate **full** marks.
 - (4) Assume suitable **data**, if required.
 - (5) Illustrate answers with **sketches** wherever required.

1. Explain briefly (any four) [20]
 - (a) Explain the various types of triggering methods of SCR briefly. Which is the Universal method and Why.
 - (b) What are different performance parameters for controlled rectifiers. Explain their significance.
 - (c) Need for cooling of a Power device.
 - (d) Explain Importance of dv/dt and di/dt ratings along with proper protection circuit in case of SCR.
 - (e) Explain the basic requirements for the successful triggering of Thyristor in detail.
2. (a) Explain the operation of single phase half-controlled bridge converter with resistive load and inductive load with the associated waveforms. Derive the expression for average load voltage, average load current and RMS load voltage. [10]
 - (b) A single phase fully controlled bridge converter supplies an inductive load. Assuming that the output current is virtually constant and is equal to I_d , determine the following performance measures, If the supply voltage is 230V and if the firing angle is maintained at $\pi/6$ radians [10]
 - (i) Average output voltage
 - (ii) Supply RMS current
 - (iii) Fundamental power factor
 - (iv) Supply power factor
 - (v) Voltage ripple factor
3. (a) Draw and explain the simple SCR series inverter circuit employing Class A type commutation. Draw and discuss the important waveforms. State the limitations of this series inverter. [10]
 - (b) Design a series Inverter circuit for operation in the frequency range 1 to 5 KHz, the load resistance may vary from 25Ω to 100Ω . The peak load current is limited to 3A and the supply voltage is 100V. [10]
4. (a) With the circuit diagram and output voltage waveforms, explain the principle of operation & working of Jones chopper. [10]
 - (b) Design Jones chopper circuit for optimum frequency considerations to meet the following specifications: [10]

Source voltage	$E_{dc} = 200V$
Load current	$I_0 = 50A$
	$t_q = 200 \mu s$
5. (a) Explain the method of speed control of 3 phase slip ring Induction motor using slip power recovery scheme. [10]
 - (b) Explain with block schematic the working of microcontroller based control circuit of motor controller. [10]
6. (a) Based on either Inverse Cosine or Pedestal and Ramp principle. Suggest a detailed firing circuit to trigger four SCR's of single phase fully controlled bridge converter. Comment on how synchronization, Isolation and phase control is achieved. [12]
 - (b) Draw and explain the Fan regulator circuit using DIAC and TRIAC. Draw waveforms across load & TRIAC. [8]
7. Write short notes: (any three) [20]
 - (a) Commutation circuit for SCR
 - (b) IR compensation
 - (c) V/F control for Induction motor
 - (d) Effects of source inductance on output voltage of full controlled rectifier.

○ ○ ○

Power Electronics – May 2008

Time : 3 Hrs.]

[Marks : 100

- N.B.**
- (1) Q. No. 1 is **compulsory**.
 - (2) Attempt any **four** questions from the remaining **six** questions.
 - (3) **Figures** to the **right** indicate **full** marks.
 - (4) Assume **suitable** data if **required**.
 - (5) Illustrate answers with sketches wherever **required**.

1. Explain in brief the following : [20]
 - (a) What is latching current, holding current, forward breakover voltage, reverse breakover voltage of a thyristor.
 - (b) State the conditions for getting inversion mode of operation in case of line commutated converters.
 - (c) What are different performance parameters for controlled rectifiers? Explain their significance?
 - (d) Explain the turn “on” and turn “off” characteristics of SCR.
 - (e) Compare BJT, SCR and IGBT.

2. (a) Explain the full wave ac control using Triac and Diac. Draw waveforms. [10]
 (b) Draw and explain the working of 3-phase uncontrolled bridge rectifier with purely resistive load and derive the expression for average output voltage and sketch the input and output waveforms with proper sequence of conducting diodes. [10]
3. (a) What is effect of source inductance on the output voltage of full wave controlled rectifier. Obtain an expression for the output voltage with the effect of source inductance. [10]
 (b) A 1-phase fully controlled rectifier is operated with a resistive load $R = 10 \text{ ohm}$, the input voltage to the bridge is 230 V . Calculate the following : [10]
 (i) Average load voltage (iii) Average and runs load current
 (ii) Runs load voltage (iv) Form factor and ripple factor the firing angle $\alpha = 60^\circ$
4. (a) Explain the operation of Jones Chopper with waveform across load, and capacitor voltage obtain an expression for circuit turn "off" time available so as to select SCRs with proper turn off time ratings. [10]
 (b) The commutating components in a Jones Chopper circuit are $C = 30 \text{ microfarad}$, $L_1 = 60 \text{ microhenry}$ and $L_2 = 60 \text{ microhenry}$. If the supply voltage is 220 V . Find the highest permissible turn off time for the main Thyristor. [10]
5. (a) Explain with diagram the working of parallel inverter. Explain the need for feedback diodes and pulse train for firing SCR's draw capacitor and load voltage waveforms. [10]
 (b) In the basic series inverter circuit if the component values are $L = 40 \text{ } \mu\text{H}$, $C = 5 \text{ } \mu\text{F}$, $R = 4\Omega$. [10]
 Calculate the maximum frequency of operation if the total "off time" per cycle of inverter output is $100 \text{ } \mu\text{s}$.
6. (a) Draw and explain the variable voltage and variable frequency (V/F) method of speed control for 3-phase squirrel cage induction motor. What is the significance of (V/F) ratio control ? [10]
 (b) The speed of 10 hp separately excited dc motor is controlled by a single phase full converter the rated armature current is 40 A . $R_a = 0.3 \text{ ohm}$. The ac supply voltage is 260 V . The motor voltage constant is 0.182 V/rpm . While in motoring action with back emf of 192 volts , the polarity of its is reversed for regenerative action. Calculate (i) Firing angle to keep the motor current at its rated value. (ii) The power feedback to the supply. [10]
7. Write short notes on any **three** of the following : [20]
 (a) Ramp and pedestal scheme for triggering SCR circuits
 (b) Commutation circuits of SCR
 (c) IR compensation
 (d) Cooling methods of power semiconductor devices



Power Electronics – December 2008

Time : 3 Hrs.]

[Marks : 100

- N.B.** (1) Question No. 1 is compulsory.
 (2) Attempt any **four** questions from the remaining.
 (3) Assume **suitable** data if **necessary**.
1. (a) Is it possible to obtain Inversion mode operation in case of semiconverter feeding active load. Justify the answer. [20]
 (b) Compare IGST and SCR.
 (c) A thyristor is triggered by pulse train of 5 KHz . Duty Ratio of pulse train in is 0.5 . If allowable average Gate Power is 100 watts . Calculate the true maximum allowable gate drive power.
 (d) Explain $\frac{dv}{dt}$ and $\frac{di}{dt}$ rating along with proper protection circuit for SCR.
2. (a) Explain pulse triggering method using UJT synchronized circuit for full wave (midpoint) configuration with neat diagram. [10]
 (b) In case of F.C.B.R. (single phase) feeding an active load, assuming constant output current. Draw the following waveforms : [10]
 (i) output voltage (ii) output current
 (iii) supply current (iv) voltage across any SCR
3. (a) A 3 phase full wave converter bridge is connected to supply voltage of 230 V per phase and frequency of 50 Hz . The source inductance per phase i.e. L_S is 4 mH . The load current is 20 Amp . If the load consists of d.c. voltage source of 400 volt with internal resistance of 1Ω . Calculate : (i) firing angle delay (ii) overlap angle. [10]
 (b) Explain the operation of A.C. phase control circuit using Triac-Diac for 1 amp . Dimmer applications. Draw the waveform across load. [10]
4. (a) Why commutation failure may occur in case of Jones chopper ? How it can be avoided? [10]
 (b) In a basic step down d.c. chopper circuit input voltages is 230 V , $R = 10\Omega$, drop across chopper is 2 volt . Duty cycle is 0.4 . Determine (i) Average output voltage (ii) rms output voltage (iii) chopper efficiency. [10]

5. (a) Explain the operation of complementary commutation circuit. Draw the waveform across any one SCR and capacitor. [10]
 (b) Explain the operation of basic series inverter and obtain an expression for turn off time available of W_0 and W_r . [10]
6. (a) Explain microcontroller based closed loop speed control method of D.C. Motor. [10]
 (b) Explain v/f control method for speed control of induction motor. [10]
7. Write short notes on (any **three**) : [20]
 - (a) Triggering circuit using IC TCA 785
 - (b) Performance parameters of uncontrolled rectifier
 - (c) Isolation technique
 - (d) IR compensation techniques.



Power Electronics – May 2009

Time : 3 Hrs.]

[Marks : 100

- N.B.:** (1) Question No. 1 is **compulsory**.
 (2) Attempt any **four** questions from remaining.
 (3) Assume **suitable** data if **necessary**.

1. Explain in brief (any four) [20]
 - (a) Explain two transistor Analogy of SCR and obtain an expression for Anode Current.
 - (b) A thyristor is triggered by a pulse train of 5 KHz. Duty Ratio of pulse train is 0.5. If allowable average gate power is 100 watts. Calculate the true maximum allowable gate drive power.
 - (c) Compare IGBT and SCR.
 - (d) Is it possible to obtain inversion mode operation, in case of semiconverter feeding highly inductive load. Justify your answer.
 - (e) Explain importance of $\frac{dv}{dt}$ and $\frac{di}{dt}$ ratings along with proper protection circuit for SCR.
2. (a) In case of fully Controlled Bridge Rectifier (single phase) assuming continuous and ripple free output current, feeding an active load. Draw the following waveforms at $\alpha = 30^\circ$. [10]
 - (i) V_{out} ie. Output voltage
 - (ii) V_{SCR} ie. voltage a/c any SCR
 - (iii) I_{OUT} ie. Output Current
 - (iv) I_S ie Input Supply Current
 (b) UJT synchronized circuit is used to trigger SCRs in full wave controlled (midpoint) rectifier. Input voltage is 230 V, 50 Hz, output d.c. voltage variation is required from 100 to 150V. Find the range of firing angle and its corresponding value of R required in triggering circuit. [10]
 UJT Data : $\eta = 0.63$, $V_{BB} = 18$ volt, $C = 0.1 \mu f$.
3. (a) A 3 phase full wave converter bridge is connected to supply voltage of 230 V per phase and frequency of 50 Hz. The source inductance per phase i.e. L_s is 4 mH. The load current is 20 Amp. If the load consists of d.c. voltage source of 400 V with Internal resistance of 1Ω . Calculate (i) firing angle delay (ii) overlap angle [10]
 (b) Explain the operation of A.C. phase control circuit using Triac Diac for lamp Dimmer application. Draw the waveform across load. [10]
4. (a) In a basic step down d.c. chopper circuit, input voltage is 230 V, $R = 10\Omega$, drop across chopper switch is 2 Volt and duty cycle is 0.4. [10]
 Determine – (i) Average output voltage
 (ii) rms output voltage
 (iii) Chopper efficiency
 (b) Draw the diagram of Jones Chopper. Explain from the diagram, how commutation voltage is developed across capacitor if – (i) SCR1 is triggered first and if (ii) SCR2 ie. Auxiliary SCR is triggered first. [10]
5. (a) Draw the diagram of basic Series Inverter. Explain its operation with output waveform. Obtain an expression for turn off time available in terms of w_0 and w_r . [10]
 (b) Explain the operation of complementary commutation circuit. Draw the waveform across any one SCR and capacitor. [10]
6. (a) Speed of D.C. Motor is controlled by Armature voltage control using fully controlled bridge converter at $\alpha = 60^\circ$. Motor specifications are $R_a = 0.25\Omega$, $R_f = 150\Omega$, $I_a = 20$ Amp continuous and ripple free, Input is 230V, 50Hz. Now to operate the Motor in Inversion mode, the polarity of back emf is reversed by reversing the Polarity of field current, determine – [10]
 - (i) Delay angle to maintain armature current constant
 - (ii) Power fed back to supply
 (b) Explain the speed control method of Slip Ring Induction Motor using Slip Power recovery Scheme. [10]

7. Write short notes on (any three) [20]
- Microcontroller based speed control of D.C. Motor
 - Triggering circuit using IC TCA 785
 - Performance parameters of Uncontrolled Rectifier
 - Types of chopper as per Quadrant of operation

○ ○ ○

Power Electronics – December 2009

Time : 3 Hrs.]

[Marks : 100

- N.B.:**
- Question No. 1 is compulsory.
 - Attempt any **four** questions from remaining **six** questions.
 - Figures** to the **right** indicate **full** marks.
 - Assume **suitable data** if **required**.

- What are the various triggering methods of SCR ? Explain one in detail. [20]
 - Explain how dv/dt and di/dt protection circuits are useful for SCR.
 - Define latching current, holding current, forward break over voltage, reverse break over voltage and write value of general rating of SCR.
 - Explain the operation of basic series Inverter with relevant waveforms and state its limitations.
- Explain Latch up in IGBT. How does the latchup take place and how to avoid latch up? [10]
 - Compare (i) SCR and IGBT (ii) SCR and TRIAC (iii) SCR and GTO. [10]
- Explain need of isolation in Power Electronics ? Draw the various circuits available for isolation. [10]
 - The half wave converter is feeding resistive load and firing angle is $\alpha = \pi/2$. [10]
Find : (i) Rectification efficiency (ii) Form factor
(iii) Ripple factor (iv) TUF and
(v) PIV of thyristor.
- Explain the operation of Jones chopper along with waveform across load and capacitor voltage. Obtain an expression for circuit turn off. [10]
 - Jones chopper $C = 40\mu\text{f}$, $L1 = 100\mu\text{H}$ (series with capacitor), $L2 = 30\mu\text{H}$, $V_s = 110\text{V}$. Find out the highest turn off time for main SCR T1 and maximum load current that can be safely commutated. [10]
- Explain different forced commutation circuits. [10]
 - The series inverter has $L1 = L2 = 50\mu\text{H}$, $C = 6\mu\text{f}$, $R = 2\Omega$. The d.c. input voltage is $V_s = 220\text{V}$ and the frequency of output voltage is $f = 7\text{KHz}$. The turn off time of thyristor is $t_q = 10\mu\text{sec}$. Determine : (i) Circuit turn off time t_{off} [10]
(ii) The maximum permissible frequency f_{maximum}
(iii) The peak – peak capacitor voltage
(iv) The peak load current I_p .
- Explain Variable voltage and variable frequency (V/F) method of speed control for 3-phase induction motor. [10]
 - Explain Microcontroller based speed control of D.C. Motor. [10]
- Write short notes on : [20]
 - Cooling methods of power semiconductor devices
 - IR compensation
 - Modified series inverter
 - Parallel inverter.

○ ○ ○